

Promate®

Operator Manual

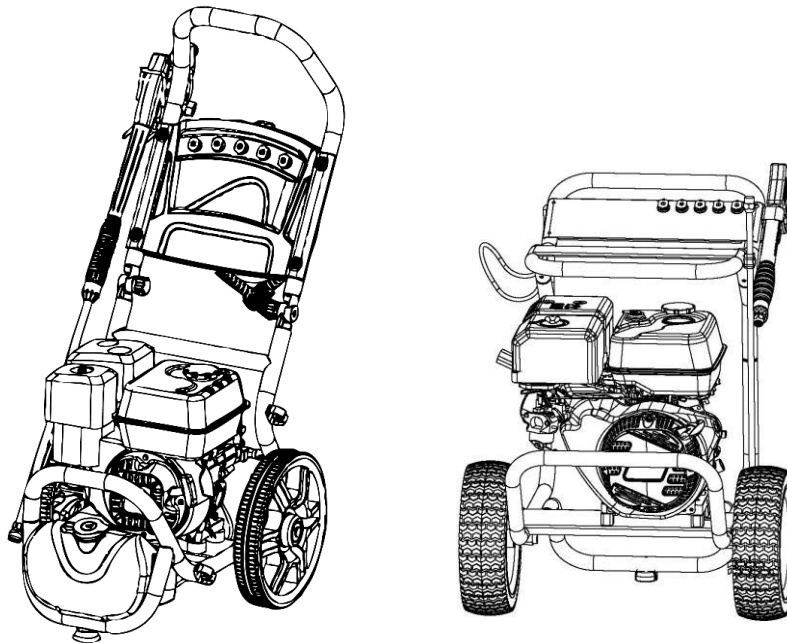

GASOLINE PRESSURE WASHER

IMPORTANT – Please make certain that persons who are to use this equipment thoroughly read and understand these instructions and any additional instructions provided prior to operation.

Record the model and serial numbers of your pressure washer below:

Model No. _____ Serial No. _____

FOREWORD













Thank you for purchasing our product. This operator manual is for proper handling, minor checking and maintenance of the pressure washer. Before using your pressure washer: Please read these instructions completely and carefully in order to make the best use of it as well as operate it safely. Due to constant efforts to improve our products, certain procedures and specifications are subject to change without notice, if you have any questions, please contact Promate Service.

CONTENTS

1	Safety Precautions	3
2	Pressure Washer Terminology	4
3	Assembly Attachments	4
4	Preparing the Pressure Washer	7
5	Starting the Pressure Washer	9
6	Operating the Pressure Washer	9
7	Maintenance and Storage	12
8	Specifications	17
9	Troubleshooting Guide	17
10	Service Information	21
	Pressure Washer Exploded View	22-27

1. SAFETY PRECAUTIONS

The electric power generated by the gasoline engine of the pressure washer can be used for many kinds of electric appliances. When handling it, please keep to the following matters. Please make sure you review each precaution carefully.

	READ OPERATING INSTRUCTIONS: Read and understand tool labels, safety warning and precaution in this manual before operating the tool.
	FIRE HAZARD: Heat from engine exhaust can ignite combustible materials, building structures or gas tanks resulting in a fire. Place the tool on a flat surface a safe distance from building or other combustible material. Ensure is directed away from tool.
	ELECTRICAL SHOCK: This tool produces hazardous electrical voltage.
	WEAR APPROVED EYE PROTECTION: This tool has rotating and moving parts that could become airborne if damaged.
	POISONOUS FUMES: This tool uses a gasoline powered engine that produces poisonous fumes from its exhaust.
	EXPLOSION HAZARD: Fuel and its vapors are extremely flammable and explosive.
	ROTATING PARTS: Starter and other rotating parts on this tool can entangle loose items or accessories resulting in moderate to severe injury.
	HOT SURFACES: Engine muffler and other engine parts can become very hot.
	KICKBACK: Starter cord can kickback (recoil) very rapidly.
	UNIT IS HEAVY: Take care when lifting or moving unit.
	INJECTION HAZARD: Pressure washers can produce puddles, fluid streams severe enough to penetrate animal or human skin.
	SLIPPING AND FALLING: Pressure washers produce puddles of slippery liquid that can result in falls. Kickback from spray wand can result in falls when using unstable platforms.

WARNING

Improper and unsafe use of this pressure washer can result in death, fire, and/or body injury. This instructions manual contains important information about the products safety.

2. PRESSURE WASHER TERMINOLOGY

Following are the common terms associated with the use of pressure washers:

- **PSI:** Pounds per square inch-common unit measure used for water pressure, air pressure, hydraulic pressure and pounds of force.
- **GPM:** Gallons per minute (liters per minute[metric])-common unit measure used for flow rate of water.
- **Bypass Mode:** In mode, high pressure pump recirculates water because spray gun trigger is not squeezed.
- **Thermal Relief Valve:** When in Bypass Mode: this valve releases a jet of water to prevent water temperatures from reaching harmful levels that damage the pump. Once the water has cooled, the temperatures from reaching harmful levels that damage the pump. Once the water has cooled, the thermal relief valve will reset itself. DO NOT allow pump to run without spraying in (In Bypass Mode) for more than 5 minutes.

3. ASSEMBLY/ ATTACHMENTS

This pressure washer requires some assembly and will be ready for use after servicing with manufacturer approved oil and fuel. If you have any problems with the assembly of your pressure washer, please call Promate Service for assistance, have the model, revision, and the serial number from the data tag available.

3-1. Pressure Washer

WARNING! Unit is heavy. DO NOT attempt to lift and remove the pressure washer unit from the carton.



1. Using a boxcutter, open the carton completely by cutting the four corners allowing the sides to lay flat. Leave the pressure washer on the carton.
2. Remove all the items except the pressure washer from the box and inspect for completeness (See Functional Description).
3. Carefully tip the pressure washer forward and place on its front side and proceed to assemble the unit using the provided tools.
4. Insert the shaft through the holes in the bottom frame tubing as shown.
5. Assemble the wheels to the shaft, insert the Cotter Pins using a pair of pliers (not provided).
6. Assemble the Legs to the bottom frame tubing (using the nuts and Bolts) as shown. Tighten all mounting hardware.
7. After completion of wheel/leg assembly. Carefully place the pressure washer on its wheels and legs.
8. Pull the handle lock pic and fully raise the handle upright. Release and snap the locking hole in the frame.
9. Assemble the top and bottom gun holders (using the nuts and Bolts) to the frame as shown. Tighten all mounting hardware.

3-2. Pressure Hose to Pressure Pump

Pull back the high-pressure outlet fitting collar, Insert Pressure Hose inside the fitting

and release collar. Tug on the hose to make sure it is secured.

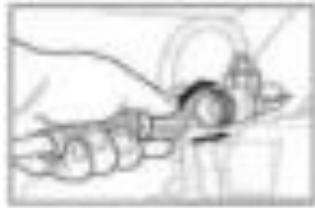

3-3. Pressure Hose to Spray Gun

1. Pull slip ring on female quick-disconnect fitting of high-pressure hose back.
2. Insert male quick-disconnect fitting on spray gun into female quick disconnect on high pressure hose.
3. Release slip ring on female quick-disconnect and twist. Listen for "click" to ensure both quick disconnects are coupled.
4. Pull high pressure hose and spray gun in opposite direction to ensure they DO NOT separate.



3-4. Spray Wand to Spray Gun

1. Remove the protective plastic cap at the inlet of the wand.
2. Thread spray wand onto spray gun.
3. Tighten the nut to secure the wand to the Gun.

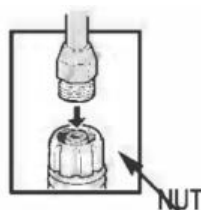

3-5. Selecting the Right Nozzle

NOTE

To prevent damage to your surface and to select and nozzle size for your application, always start with lowest pressure nozzle size (White) and continue changing to the higher nozzle size until the best work result is achieved.

The Pressure Washer comes furnished with five spray nozzles. Each nozzle is color coded and delivers a specific spray pattern and pressure for a particular cleaning job. The size of nozzle determines the size of the fan spray and the pressure out of the nozzle.

0° Nozzle – Red: This nozzle delivers a pinpoint of pressurized water and is extremely powerful. It covers a small area of cleaning only, and should only be directed at surfaces that can withstand high pressure such as metal or concrete. DO NOT use this nozzle to clean wood.

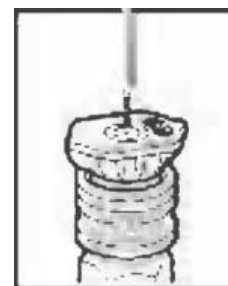

15° Nozzle – Yellow: This nozzle delivers a powerful 15-degree spray pattern for intense cleaning of small areas. This nozzle should only be used on areas and materials that can withstand high pressure.

25° Nozzle – Green: This nozzle delivers a 40-degree spray pattern and a less powerful stream of water. This nozzle should only be used on areas that can withstand pressure from this nozzle.

40° Nozzle – White: This nozzle delivers a 40-degree spray pattern and a less powerful stream of water. This nozzle can cover a wide area and should be used for most general cleaning Jobs.

Chemical Nozzle – Black: This nozzle is used to apply special chemicals and cleaning solutions. This nozzle produces the weakest pressure stream. The Pressure Washer nozzles are stored in receptacles on a panel mounted to the handle of the washer. Colors on the panel identify the nozzle location and spray panel.

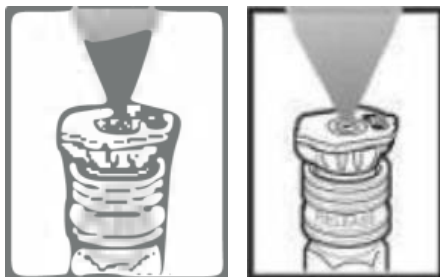

3-6. Nozzles to Spray Wand

⚠ WARNING

- Never place hands in front of nozzle. Never grasp hose or fittings during pressure washer operation. Never attempt to attach or remove spray wand or hose fittings while pressure washer system is pressurized.
- Turn off pressure washer and lock the gun trigger before attempting to change pressure nozzles.

1. To attach nozzle into female quick-disconnect spray wand and press to snap in the nozzle.
2. To detach, slide down slip ring on female quick disconnect to eject the nozzle.

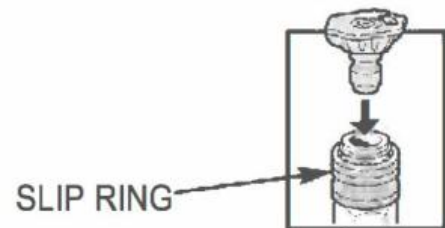

3-7. Pressure Pump to Water Supply

1. Connect the Garden hose to the water supply and turn water supply on to fill the hose with water and also remove any debris in the hose. Turn OFF water supply.
2. Make sure that the filter inside pressure washer water inlet is clean and undamaged. Thread the Garden hose fitting into water hose inlet.

Hand tighten the inlet nut.

3. Turn on water supply.

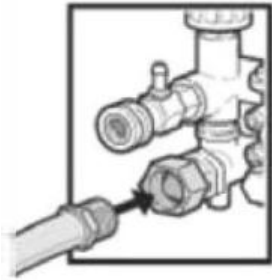

NOTE

The pressure washer requires a minimum of 20 PSI and a flow rate of 5 GPM.

4. PREPARING THE PRESSURE WASHER

The pressure washer is shipped with shipping oil plug to prevent oil leakage from the pump during shipping. To replace the shipping plug with the Breather plug (provided) perform the following:

WARNING

Failure to remove shipping plug and replace it with the dipstick/oil plug will damage pressure pump. Failure to add pump Breather Plug could void warranty.

1. Using a wrench, remove shipping plug from pressure pump. Discard shipping plug.
2. Remove pump Breather plug from parts bag and insert it into pressure pump.
3. Tighten pump Breather plug securely

by hand. DO NOT use wrench to lighten. Using a wrench to lighten pump Breather Plug could strip threads.

4. Use the oil level glass window on the side of the pump to ensure that pump oil is at mid-point or above.
5. Add oil to pressure pump if level is below the prescribed level. Use only 30-weight non-detergent oil.

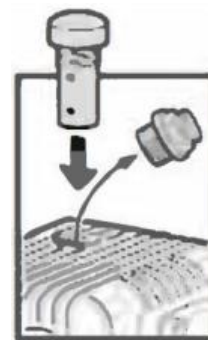

4-1. Adding Engine Oil

1. Move the pressure washer OUTSIDE and place on flat and level surface.
2. Remove the engine oil dipstick and place funnel in the oil reservoir.
3. Pour the supplied engine oil (30 weight) **until oil level reaches the threads inside the oil reservoir.**
4. Hand tighten the oil dipstick and clean any spilled oil.



4-2. Low Oil Sensor

To prevent engine damage caused by an insufficient amount of oil in the crankcase, engine is equipped with low oil sensor. If the oil is below the safe amount, the sensor will activate and will prevent engine start-up or will stop the running engine.

If pressure washer shuts off and the oil level is within specifications, check to see if pressure washer is sitting at an angle that forces oil to shift.

Place on an even surface to correct this. If engine fails to start, the oil level may not be sufficient to deactivate low oil level sensor. Add oil as described above.

4-3. Adding Fuel

1. Move the pressure OUTSIDE and place on a flat and level surface.
2. Remove the gas tank cap. Carefully add 87 Octane (or higher) grade gasoline to the tank. DO NOT overfill. Leave room for the gasoline to expand.
3. Replace and hand tighten gas cap and wipe off any spilled fuel.

WARNING

Fuel and fuel vapor are extremely flammable and explosive.



Fire or explosion from misuse of fuel can cause severe burns and even death.



Failure to use fuel as recommended in this manual will void the warranty.

When adding fuel to the Pressure Washer, observe the following:

- DO NOT USE unapproved gasoline such as E85 (85% ethanol/15%gasoline)
- DO NOT mix oil with gasoline.
- DO NOT modify engine to run on alternate fuels.
- Turn pressure washer OFF and let it cool for at least two minutes before removing fuel cap. Loosen fuel cap slowly to release pressure.
- Keep fuel away from sparks, open flames, pilot lights, heat and other ignition sources.
- DO NOT light a cigarette or smoke near open fuel tank or container.
- Clean area around fuel fill cap and slowly remove cap to allow any pressure to escape. Install fuel cap and allow any spilled fuel to evaporate before starting engine.
- DO NOT Overfill fuel tank. Slowly add unleaded gasoline (A) to fuel tank (B). Use extreme caution not to fill fuel above baffle (C). This allows appropriate space for fuel expansion.

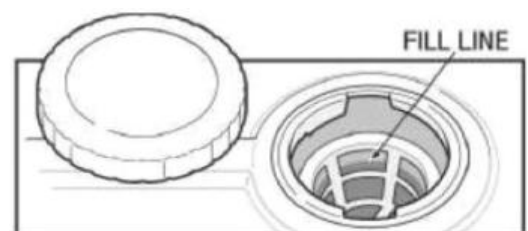

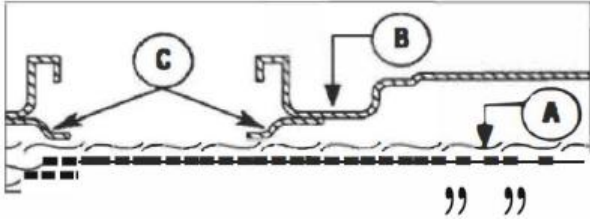

4-4. Using the Pressure Washer at High Altitudes

Engine carburetor is factory adjusted for optimum operation from 0 to 1500 meters above the sea level. Approximately 10% of power drop in the engine is expected with respect to each 1000 meters of altitude. To maintain proper emissions compliance and optimum performance & fuel consumption, high altitude adjustment may be required for altitudes above 1500 meters. If adjustment is required, contact Promate Service.

5. STARTING THE PRESSURE WASHER

NOTE

Prior to starting the Pressure Washer, make sure to have the following:

1. Selected a proper size nozzle for the job at hand (see **"Selecting the Right Nozzle for the Job"**).
2. Attached the pressure washer to the water source and turned on the source (see **"Pressure Pump to Water Supply"**).
3. For your protection, wear the protective safety glasses provided.
4. Move the pressure washer outside in a fully ventilated area.
5. Place the pressure washer on a FLAT and level surface and close to the working surface. Keep a minimum of 5 ft. (1.5 meters) CLEARANCE on all sides of the engine including top. Face the engine exhaust outlet AWAY from dwellings.
6. Make sure the Throttle level is set to the "FAST" position (left).

7. Slide the fuel valve lever to "ON" position (right) to allow the fuel to flow to the engine.
8. Slide the Choke lever to "START" position (left).
9. Turn the Engine ON/ OFF switch clockwise to ON position.
10. Point nozzle to a safe direction and squeeze the spray gun trigger to allow for easier engine start.
11. To start the engine, pull starter cord slowly until resistance is felt, then pull rapidly to avoid kick back. Repeat until the engine starts to run. Then, release the trigger.
12. Slide the choke lever to "RUN" (right) position.

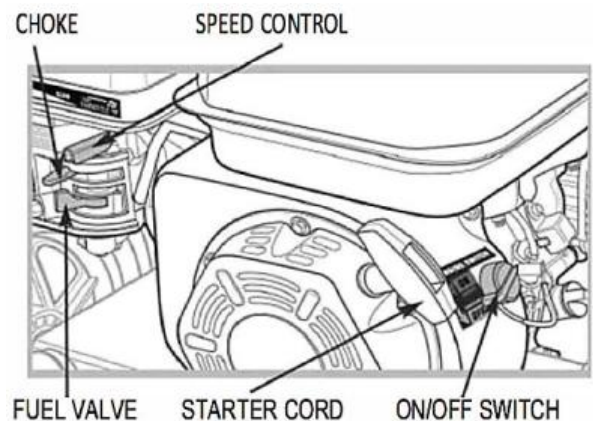

6. OPERATING THE PRESSURE WASHER

WARNING

- DO NOT leave pressure washer in by-pass mode for more than two minutes at a time. Water temperature inside the pressure pump will rise to a dangerous level resulting in damage to the internal components of the pump. Failure to follow this warning will void warranty.

- DO NOT run the pressure pump without the water supply connected and turned on.
- Damage to the pressure washer resulting from failure to follow this Instruction WILL void the warranty.
- ALWAYS wear approved safety glasses when operating pressure washers. Spray can splash back or propel objects, including incorrectly attached accessories.

6-1. Using the Spray Gun

To engage the Trigger lock, pull the lock up until it clicks into the slot.

To disengage the Trigger lock, push the lock down and into its original position.

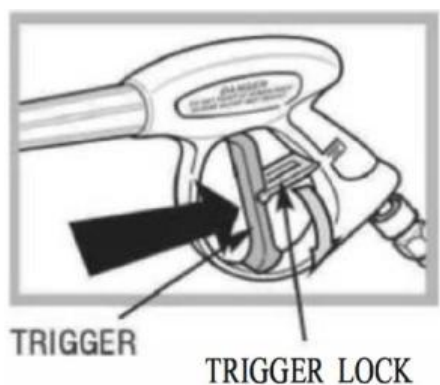

6-2. To Operate the Trigger

1. Squeeze the trigger to start water flow through the nozzle.
2. Release the trigger to stop water flow.

6-3. Washing / Cleaning

1. Firmly grip Spray Gun with Bolt hands.
2. Point the nozzle to a safe direction and squeeze the Spray trigger to allow the pump top purge air impurities in the

system and then redirect the nozzle to the working surface.

3. When finished, release the gun trigger to stop water flow.

6-4. Usage Tips

- For most effective cleaning, keep spray nozzle from 8 to 24 inches away from cleaning surface.
- If you get spray nozzle too close, especially using high pressure mode being cleaned, you may damage surface being cleaned.
- DO NOT get closer than 6 inches when cleaning tires.

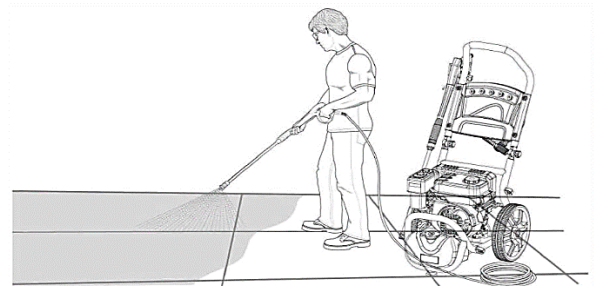

6-5. Pressure Adjustment

Increase distance: To vary the pressure on the surface being cleaned, vary the distance between spray wand and the surface being cleaned.

Change pressure wand nozzle: Completely shut down Pressure Washer and stop gasoline engine, Change Spray Nozzle for desired pressure (see **3-5. Selecting the Right Nozzle**). Then, restart the engine.

Adjust pump pressure regulator: The pump

pressure regulator allows pressure adjustment at the pump. Turn pressure regulator knob on pressure pump counterclockwise/clockwise to decrease/increase pressure.

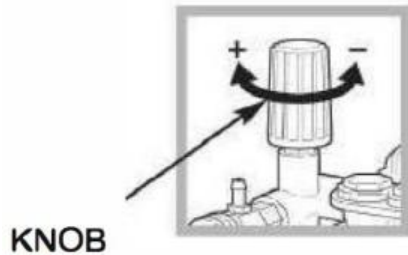

6-6. Using Chemicals and Cleaning Solvents

NOTE

- Use only soaps and chemicals for use with Pressure Washer. DO NOT USE CHLORINE BLEACH.
- Chemicals, Soaps and cleaning solvents will not siphon when a high-pressure nozzle is used. Use the chemical Nozzle (Black).

To Apply Detergent

1. Prepare detergent solution as recommended by the manufacturer.
2. Remove the detergent tank lid located in front of the pressure washer.
3. Fill tank with prepared detergent solution. A small funnel may help with this task. Replace the detergent tank lid.
4. Lock the trigger and attach the Detergent Nozzle (Black) to the Wand.
5. Unlock the trigger and squeeze spray gun trigger and apply detergent to a dry surface, starting at lower portion of area to be washed and work upward, using long,

even, overlapping strokes.

NOTE

Wetting the surface first is not recommended, as it dilutes the detergent and reduces its cleaning ability.

6. Allow detergent to "soak in" for 3-5 minutes before washing and rinsing. Reapply as needed to prevent surface from drying. Do Not allow detergent to dry on surface (prevents streaking).

To Rinse

1. Replace the nozzle with an appropriate high-pressure nozzle (see **3-5. Selecting the Right Nozzle**). Squeeze the trigger and wait for the detergent to clear.
2. Keep the spray gun at a safe distance from the area you plan to spray.
3. Apply a high-pressure spray to a small area, and then check the surface for damage. If no damage is found, it is okay to continue cleaning.
4. Start at the top area to be rinsed, working down with same overlapping strokes as you used for used for washing and applying detergent.

To Flush System

When you have completed the use of detergent injection system:

1. Turn off the engine and fill the detergent tank with clean water.
2. Remove the nozzle and then turn engine back on.
3. Point the wand toward a safe direction and

squeeze the trigger to flush clean water through the detergent tank and the system until it is thoroughly clean.

WARNING

Leaving chemicals and cleaning solutions inside the pressure pump could damage it. Damages created by leaving soaps, chemicals and cleaning solutions inside the pump can void the warranty.

Cleaning Tips

- Never use the pressure washer water inlet to siphon detergent or wax.
- If you have the nozzle too far away from the surface being washed, the cleaning will not be as effective.

NOTE

DO NOT get closer than 6 inches when cleaning.

6-7. Shutting Down the Pressure Washer

1. Top stop the engine switch on the side of the engine to OFF position.
2. Slide Fuel Valve lever to the left to stop fuel flow to the engine.
3. Turn off the water supply and disconnect Garden hose from the pressure washer.
4. Squeeze the gun trigger to release any remaining water in the system.
5. Store spray gun on the side and hoses inside the hose housing inside the handle.

CAUTION

- Allow engine to cool down before folding handle.
- Never turn off the water supply with the engine running. This will cause the pressure pump to overheat, resulting in internal damage.
- The pressure washer must be properly stored. Refer **7. Maintenance and Storage**.

7. MAINTENANCE AND STORAGE

7-1. Maintenance

Regular maintenance will improve performance and extend life of pressure washer.

The Pressure Washers' warranty does not cover items that have been subjected to operator abuse or negligence. Only by maintaining pressure washer in accordance with instructions in this manual will the full value of the warranty be honored.

Some adjustments will need to be made periodically to properly maintain the pressure washer. All service and adjustments should be made at least one time each season. It is important that the maintenance chart below be followed.

Engine Maintenance Schedule

Frequency	Items	Each time	Every month or 20 Hrs	Every 3 months or 50 Hrs	Every 6 months or 100 Hrs	Every year or 300 Hrs
Engine Oil	Check oil level	x				
	Replace				x	
Air Cleaner (Filter)	Check	x				
	Clean			x	x*	
	Replace-Clean					x
Deposit Cup					x	
Spark Plug	Clean-Adjust				x***	
	Replace					x
Spark Arrester	Clean				x	
Idling	Check-Adjust					x
Valve Clearance	Check-Adjust					x
Fuel Tank	Clean					x
Fuel Supply Line	Check	Every two year (Replace if necessary**)				

* Recommended to be performed more often than in the schedule if operated in dusty environments.

** Recommended to be performed by authorized dealers.

*** Adjust gap to 0.6 to -0.7 mm

Checking Pressure Pump Oil

1. Check oil site gauge on pressure pump. Oil should cover site gauge.
2. Remove dipstick/oil plug from crankcase and wipe clean.
3. Oil level is correct if it covers lower half of dipstick.

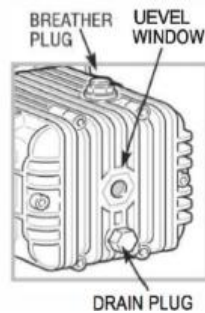

Changing Pressure Pump Oil

1. Place container under pressure pump oil drain plug.
2. Using a wrench, loosen oil drain plug.
3. Remove oil drain plug and drain oil into container.
4. Replace oil drain plug and retighten using the wrench.
5. Loosen and remove breather plug from top of pressure pump.
6. Add NEW 30 weight engine oil to pump case until the oil level raises above the midpoint on the oil level window on the side of the pump
7. Replace and hand tighten the breather plug.

Cleaning the Nozzle

Occasionally, the spray wand can become clogged with foreign materials such as dirt.

When this happens, excessive pressure can

develop. Whenever the pressure nozzle becomes partially clogged, the pump pressure will pulsate. It should be immediately cleaned.

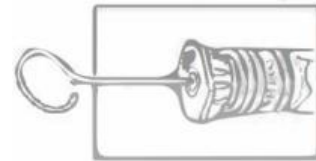

1. Make sure pressure washer is shut off and spray gun trigger is locked.
2. Remove high pressure spray nozzle from the spray wand. Using the nozzle cleaning needle (provided), remove any obstructions by inserting and carefully moving the pin back-and -forth through nozzle hole under clean running water.
3. After cleaning, remove the needle from nozzle and store for future use.
4. Reassemble pressure nozzle to spray wand.

Cleaning the Water Inlet Screen Filter

The water inlet screen filter should be checked periodically and cleaned if necessary.

1. Disconnect inlet water hose.
2. Remove filter by grasping end and pull straight back.
3. Clean screen filter by flushing both sides with water.
4. Insert screen filter back inside water inlet port.

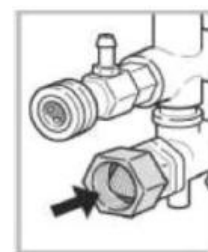

⚠ WARNING

Do not operate pressure washer without screen filter in place. Impurities entering pressure pump can cause internal damage.

Cleaning the Pressure Washer

Daily or before use inspections should include areas around and underneath pressure washer looking for signs of fuel or oil leaks. Preventative maintenance should be taken if leaks are found. Clean accumulated debris from outside and inside pressure washer. Ensure all linkages, springs and other engine controls are kept clean. Inspect cooling air slots and openings on pressure washer. Openings must be kept clean and unobstructed for peak performance of pressure washer.

Engine components should be kept clean reducing risk of overheating and ignition of accumulated debris.

- Use a damp cloth to wipe exterior surfaces clean.
- Use a soft bristle brush to loosen caked on dirt or oil.
- Use a shop-vacuum to pick up any loose dirt and debris.

7-2. Storage

⚠ WARNING

Fuel and fuel vapor are extremely flammable and explosive.



Fuel and fuel vapor are extremely flammable and explosive. Fire or explosion from misuse of fuel can cause severe burns and even death.



Engine

Gasoline fuel can become stale when stored over 30 days. Stale fuel causes acid and gum deposits to form in the fuel system or crucial carburetor parts. To Keep fuel fresh, add the provided fuel stabilizer tablets to the fuel tank (read instructions in the back for directions).

Draining gasoline is unnecessary if the fuel stabilizer is used according to the instructions that come with it. Run Pressure Washer engine for a minimum of two minutes, after stabilizers added to fuel, to allow it to circulate throughout the engine. The engine fuel can be stored up to 24 months.

NOTE

Store gasoline from one season to another unless it's been treated with fuel stabilizer. Replace fuel container, if metal, and if it begins to rust. Rust and dirt and debris can contaminate fuel supply and components resulting in poor performance and /or internal damage to engine. Fuel should be stored in newer approved plastic storage containers.

To Protect Against Rust Formation During Storage, Oil the Cylinder Bore:

- Remove spark plug and pour approximately 1/2 oz (15ml) of clean engine oil into the cylinder.
- Install spark plug and pull starter cord slowly to distribute oil.
- Make sure engine ON/OFF switch is OFF. Slowly pull the starter cord 2 to 3 times to distribute and coat the cylinder bore with oil. DO NOT start engine at this time.

⚠ WARNING

Fuel and fuel vapor are extremely flammable and explosive.



Fire or explosion from misuse of fuel can cause severe burns and even death.



Failure to use fuel as recommended in this manual will void the warranty.

Pressure Pump

1. Drain all water from pressure hose, coil and store it in cradle of pressure washer handle.
2. Drain all water from spray gun and spray wand by holding spray gun in vertical position with nozzle pointed downward. Squeeze trigger to remove fluids from spray gun and spray wand. Store in spray gun/hose holder.
3. Store chemical hose, high pressure hose and spray wand so they are protected from damage, such as being run over.

It is RECOMMENDED that you follow these steps to protect the internal seals of pressure washer when storing unit for more than 30day and/or when freezing temperatures are expected.

1. Obtain a funnel, six ounces of RV antifreeze and approximately 36 inches of Garden hose with a male hose connector on one end.

CAUTION

Use only RV antifreeze. Any other type of antifreeze is corrosive and can damage pressure pump.

2. Connect 36-inch length of Garden hose to water inlet of pressure pump.
3. Add RV antifreeze using the funnel.

4. Make sure engine ON/OFF switches OFF. Slowly pull engine starter cord several times until antifreeze comes out of pressure hose connection of pressure pump. DO NOT start engine this time.
5. Remove hose to water inlet of pressure pump.

Pressure Washer

1. Cover pressure washer with a suitable cover that does not retain moisture such as a plastic- or plastic-coated tarp.
2. Store pressure washer in a clean, dry area.

WARNING

Certain storage covers can be flammable or can melt in higher temperatures. Do not place storage cover over pressure washer unit until it has completely cooled.

Preparing for Use After Storage

1. Slowly pull the starter cord a few times to clean oil from the cylinder or to eject any antifreeze from the pump which were added prior to storage.
2. Remove the spark plug from the cylinder. Wipe oil from the spark plug and return it to the cylinder and retighten.
3. Reconnect the spark plug wire.

8. SPECIFICATIONS

Model	PW2700	PW3500
Max. Water Flow	2.2 GPM	3.3 GPM
Pump Type	Axial (AL)	Triplex
Engine Type	6.5HP / OHV	7.5HP / OHV
KW/RPM	3.8 / 3600	4.5 / 3600
Displacement	196CC	223CC
Fuel Tank Capacity	3 Liters	3 Liters
Low Oil Sensor	YES	YES
Thermal Relief Valve	YES	YES

9. TROUBLESHOOTING GUIDE

Problem	Probable Cause	Solution
Engine shuts down when running	Out of fuel	Fill fuel tank
	Low engine oil	Add oil
Engine will not run; or starts and runs roughly	Engine On/Off set to "OFF" position	Set switch to "ON" position
	Fuel valve is in "OFF" position	Turn fuel position valve
	Dirty air cleaner	Clean or replace air cleaner
	Out of fuel	Fill fuel tank
	Stale fuel	Drain fuel tank and carburetor; fill with fresh
	Spark plug wire not connected to spark plug	Connect wire to spark plug
	Bad spark plug	Replace spark plug
	Water in fuel	Drain fuel tank and carburetor; fill with fresh fuel
	Flooded	Wait 5 minutes and re-crank engine
	Excessively rich fuel/air mixture	Call Customer Service
	Intake valve stuck open or closed	Call Customer Service
	Engine has lost compression	Call Customer Service
	Low engine oil	Add oil
	Wrong fuel	Use recommended fuel
	Engine is too hot	Allow engine to cool
	Chock is in the wrong position	Change chock position
Pressure builds up after 2 pulls on starter coil or after initial USO	Squeeze the gun trigger to relieve pressure	

Problem	Probable Cause	Solution
Engine "hunts" or falters	Carburetor is running too Rich or too lean	Call Customer Service
Engine lacks power	Cylinder pressure is low	Call Customer Service
	Dirty air cleaner	Replace air filter
No pressure or Low pressure	Spray wand not set to high pressure	See 3-5. Selecting the Right Nozzle section
	Inadequate water supply	Water supply must be 7 GPM
	Hose fitting leaks during high pressure	Tighten hose fitting. Use thread sealant tape if necessary.
	Nozzle obstructed	Clean Nozzle (See 7-1. Maintenance)
	Water filter screen obstructed	Remove and clean filter.
	Defective pump	Call Customer Service
	Air in hose	Squeeze trigger to remove air
	Choke lever in choke position	Move choke to "RUN" position
	Throttle control lever is not in fast position	Move throttle control lever from fast position.
Water leaking at pump	Loose connections	Tighten connections
	Piston packing worn	Clean or replace. Call Customer Service.
	Worn or broken O-ring	Clean or replace. Call Customer Service.
	Pump head or tubes damaged from freezing	Clean or replace. Call Customer Service.
Pump will not draw chemicals	Spray wand not set to low pressure	See 3-5. Selecting the Right Nozzle section
	Chemical hose/filter clogged	Clean hose/filter
	Chemical screen not in chemical	Ensure end of chemical hose is fully submerged into chemicals
	Chemical solution too thick	Dilute chemical. Chemical solutions should have same consistency as water or replace.
	Chemical build-up in chemical injector.	Call Customer Service
No or low pressure (after period of normal use)	Worn seal or packing	Clean or replace. Call Customer Service.
	Worn or obstructed valves	Clean or replace. Call Customer Service.
	Worn unloader piston	Clean or replace. Call Customer Service.
Water Leaking at spray gun/Spray wand connection.	Worn or broken O-ring	Replace
	Loose hose connection	Tighten hose connection

Problem	Probable Cause	Solution
Water Leaking at spray gun/Spray wand connection.	Oil seals worn	Clean or replace. Call Customer Service
Oil leaking at pump	Loose drain plug	Tighten drain plug
	Worn drain plug O-ring	Inspect and replace O-ring
	Worn fill plug O-ring	Inspect and replace O-ring
	Pump overfilled	Check for correct amount
	Incorrect oil used	Drain and refill with correct type and amount
	Vent plug clogged	Clean vent plug. Use air hose to free it of blockage. If problem persists, replace vent plug.
Pump pulsates	Nozzle obstructed	Clean Nozzle (See 7-1. Maintenance)
	Air In the system	Squeeze trigger to remove air

General Info

Gas	Use fresh high-quality unleaded gasoline (minimum 87 Octane)
	Add stabilizer to fuel tank and run engine for 5 minutes before storage
Oil	Pump oil: Use only 40-450ml-weight non-detergent oil
	Engine oil: Use only 30-600 ml-weight non-detergent oil
Water	Use only cold water
	Do not operate pressure washer with clogged or missing water filler screen.
	Do not operate pressure washer without adequate water supply to pressure pump. Adequate water supply is a minimum of 20 PSI @ 5GPM
Pressure Adjustment	Pressure setting is preset at factory
	For lowering pressure, refer operation section of this manual
Pump	Squeeze spray gun trigger every 2 minutes while engine is running
	Do not allow water to freeze in pump
By-Pass Mode	Never leave unit running for more than 2 minutes without squeezing spray gun trigger. Doing so could damage pump and void warranty
*Optional Spare Parts	Pump is equipped with a thermal relief valve. If water overheats, this valve opens releasing gush of water. Afterwards, the valve opens releasing gush of water. Afterwards, the valve closes returning pump to normal operation

Hose	Do not allow hoses to come in contact with engine muffler during or immediately after use
	DO NOT pull unit by pressure hose
Engine	Do not adjust or attempt maintenance without consulting supplied engine manual or having adjustments made at an authorized service center
	Add stabilizer to fuel tank and let engine run for 5 minutes before storage
	Always turn on water before starting engine
Soap / Chemicals	Use only soaps and chemical detergents designed for pressure washer use
	Use chemical nozzle (Black) with Soap/Chemicals
Nozzle	Always keep nozzles unclogged
	Chemical/ soap solutions cannot be applied using high pressure setting. Set pressure pump to low pressure and use low pressure nozzle
Storage or Winterizing	Run clean water through chemical inlet
	Add stabilizer to any remaining fuel in fuel tank
	Do not allow water to freeze in pressure pump, spray gun, spray wand or hoses

10. SERVICE INFORMATION

HOW TO ORDER REPLACEMENT PARTS

Even quality-built equipment such as the pressure washer you have purchased will need occasional replacement parts to maintain its good condition over the years.

To order replacement parts and consumable parts, please contact Promate Service (details below) and be ready with the following information:

1. Model No., Serial No. and all specifications that are shown on the Model No./Serial No. plate.
2. Part number or numbers as shown in the Parts List section.
3. A brief description of the trouble with the pressure washer.

LIMITED WARRANTY

Warranty Coverage: Powertech Asia Pacific Inc., (the Company) warrants to the original retail customer that it will repair or replace, free of charge, any parts found by the Company or its authorized service representative to be defective in material or workmanship. This warranty covers the cost of replacement parts and labor for defects in material or workmanship.

Not Covered:

- Shipping/Handling charges for sending the product to the Company or its authorized service representative for warranty service. Shipping/Handling repaired or replaced products back to the customer; these charges must be borne by the customer.
- If a separate operator's manual and engine warranty from the engine manufacturer is included with this product, only that warranty will apply to the engine.
- Damage caused by abuse, accident, the effects of corrosion, erosion and normal wear and tear.
- Warranty is void if the customer fails to

install, maintain and operate the product in accordance with the instructions and recommendations of the Company set forth in the owner's manual, or if the product is used as rental equipment.

- The Company will not pay for repairs or adjustments to the product, or for any costs of labor performed without the Company's prior authorization.
- Consumable parts such as battery, spark plugs, and air cleaner.

Warranty Period: One (1) year from the date of purchase on products used solely for consumer applications; if a product is used for business or commercial applications,

the warranty period will be limited to ninety (90) days from the date of purchase.

For warranty service, the customer must provide dated proof of purchase and must notify the Company within the warranty period.

EXCLUSIONS AND LIMITATIONS: THE COMPANY MAKES NO OTHER WARRANTY OF ANY KIND, EXPRESS OR IMPLIED. IMPLIED WARRANTIES, INCLUDING WARRANTIES OF MERCHANTABILITY AND OF FITNESS FOR A PARTICULAR PURPOSE, ARE HEREBY DISCLAIMED. THE WARRANTY SERVICE DESCRIBED ABOVE IS THE EXCLUSIVE REMEDY UNDER THIS WARRANTY; LIABILITY FOR INCIDENTAL AND CONSEQUENTIAL DAMAGES IS EXCLUDED TO THE EXTENT

PERMITTED BY LAW.

This warranty gives you specific legal rights, and you may also have other rights which vary from state to state. Some states DO NOT allow a disclaimer of implied warranties or the exclusion or limitation of incidental and consequential damages, so the above disclaimers and exclusions may not apply to you.



CONTACT THE POWERTECH Asia Pacific Inc.,
PRODUCT SERVICE DEPARTMENT AT (02) 8 638 1569 | (+63) 9338373922
service@powertechasiapacific.com | www.facebook.com/PromateServicePH/



Parts Diagram: PW2700 Engine

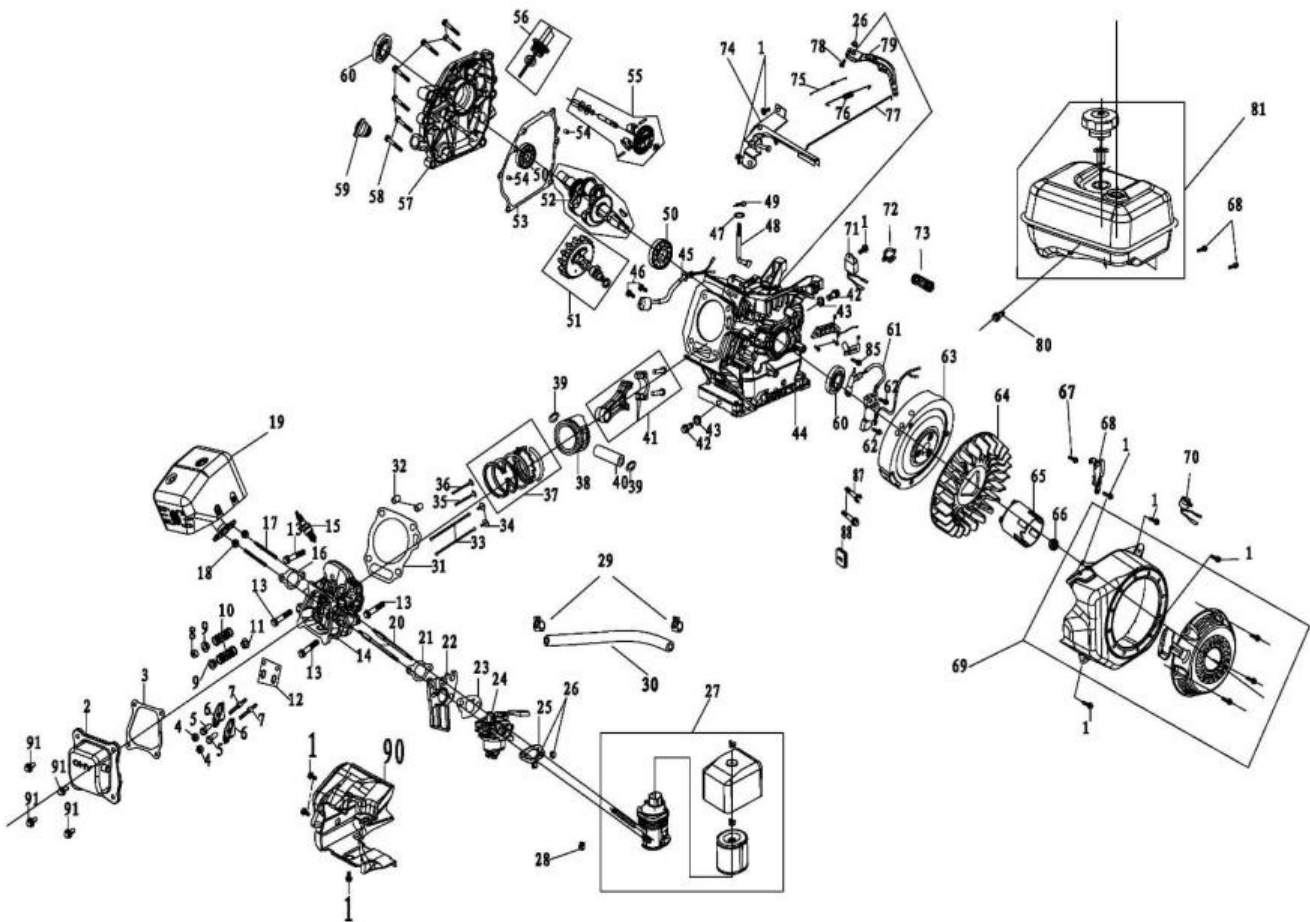

No.	Item Description	Qty
1	Bolt	10
2	Cylinder head cover assembly	1
3	Cylinder head cover gasket	1
4	Nut	2
5	Bolt	2
6	Valve rocker arm	2
7	Rocker shaft	2
8	Exhaust valve rotor	1
9	Exhaust valve spring seat	2
10	Valve spring	2
11	Intake valve oil cover	1
12	Push rod guide	1
13	Bolt	2
	Bolt	2
14	Cylinder head assembly	1
15	Spark plug	1
16	Muffler gasket	1
17	Bolt	2
18	Nut	2
19	Muffler assy	1
20	Bolt	2
21	Seal gasket	1
22	Carburetor connection block	1
23	Carburetor gasket	1
24	Carburetor assy	1
25	Air filter gasket	1
26	Nut	2
27	Air filter assy	1

No.	Item Description	Qty
28	Clamp	1
29	Clamp	2
30	Fuel pipe	0.165
31	Cylinder head gasket	1
32	Pin	2
33	Valve push rod	2
34	Valve lifter	2
35	Inlet valve	1
36	Exhaust valve	1
37	Piston ring assy	1
38	Piston	1
39	Clamp	2
40	Clamp	1
41	Rod assy	1
42	Bolt	2
43	Gasket	2
44	Crankcase	1
45	Oil sensor	1
46	Bolt	2
47	Gasket	1
48	Speed control rod	1
49	Clamp	1
50	Bearing	2
51	Camshaft assy	1
52	Crankshaft assy	1
53	Gasket	1
54	Pin	2
55	Speed control gear	1

No.	Item Description	Qty
56	Dipstick assembly	1
57	Crankcase cover	1
58	Bolt	7
59	Oil plug assembly	1
60	Oil seal	2
61	Ignition coil assembly	1
62	Bolt	2
63	Fly wheel	1
64	Fan	1
65	Starting cup	1
66	Nut	1
67	Bolt	5
68	Side windshield	1
69	Recoil starter assy	1
70	Switch	1
71	Oil alarm	1
72	Clamp	1
73	Pipe	1
74	Speed controller assembly	1
75	Spring	1
76	Spring	1
77	Speed control rod	1
79	Speed control arm	1
80	Bolt	1
81	Fuel tank assy	1
82	Nut	2
90	Wind shield cover	1

Parts Diagram: PW2700 Frame

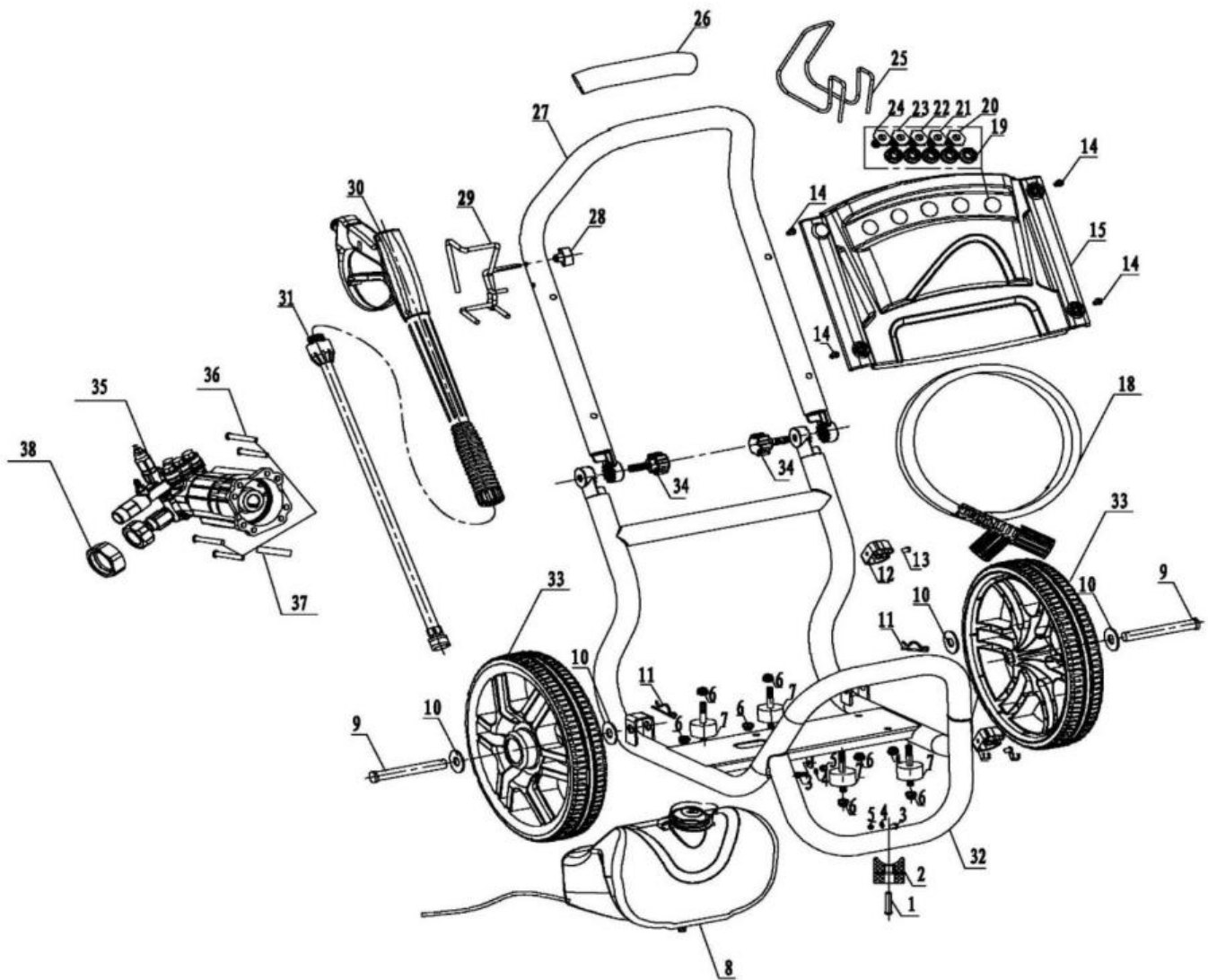

No.	Item Description	Qty
1	Bolt	1
2	Damping rubber pad	1
3	Bolt	2
4	Flat washer	2
5	Nut	2
6	Nut	8
7	Damping seat	4
8	Water tank assy	1
9	Axle	2
10	Flat washer	4
11	Clamp	2
12	Bracket	2
13	Bolt	2
14	Bolt	4
15	Panel for nozzle	1
18	Pressure hose	1
19	Nozzle holder	5

No.	Item Description	Qty
20	Nozzle black	1
21	Nozzle white	1
22	Nozzle green	1
23	Nozzle yellow	1
24	Nozzle red	1
25	High pressure pipe hook	1
26	Rubber sleeve for Handle	1
27	Handle assy	1
29	Frame for spray gun	1
30	Spray gun	1
31	Spray lance	1
32	Frame assy	1
33	Wheel assy	2
34	Bolt	2
35	Pump	1
37	Bolt	1

Parts Diagram: PW2700 Pump Kit

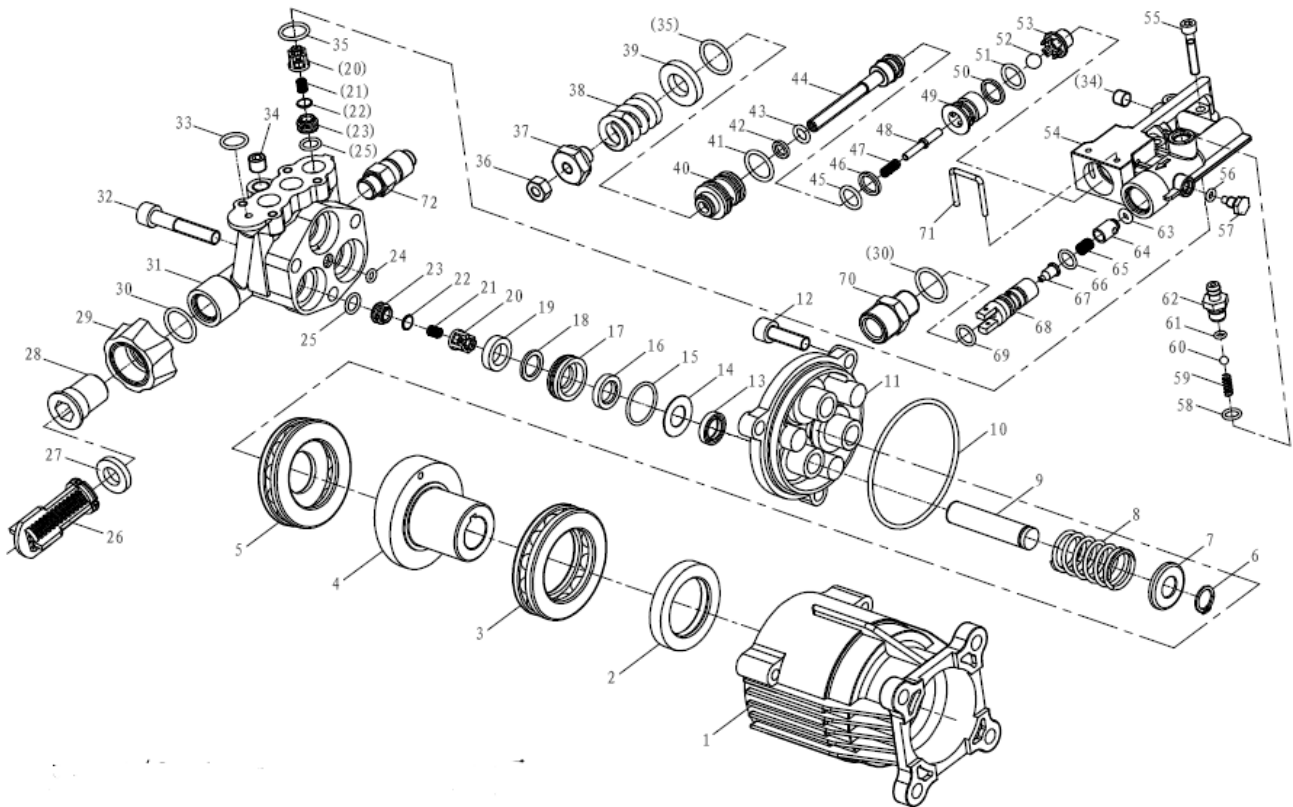

No.	Item Description	Qty
1	Swash plate box	1
2	Oil seal	1
3	Bearing	1
4	Swash plate	1
5	Bearing	1
6	Ring	3
7	Clamp	3
8	Spring	3
9	Plug	3
10	O ring	1
11	Plug Seat	1
12	Screw	3
13	Oil seal	3
14	Gasket	3
15	O ring	3
16	Secondary sealing ring	3
17	Secondary seal ring Seat	3
18	Water seal Gasket	3
19	Water seal	3
20	Valve cover	6
21	Spring	6
22	Gasket	6
23	Valve Seat	6
24	O ring	1

No.	Item Description	Qty
25	O ring	6
26	Inlet filter	1
27	washer	1
28	Inlet Connector	1
29	Nut	1
30	O ring	2
31	Pump head	1
32	Screw	3
33	O ring	1
34	Plug	2
35	O ring	4
36	Nut	1
37	Nut	1
38	Spring	1
39	Fixed Seat	1
40	Valve sleeve	1
41	O ring	1
42	Closed retaining ring	1
43	O ring	1
44	Pin	1
45	O ring	1
46	Retaining ring	1
47	Spring	1
48	Pin	1

No.	Item Description	Qty
49	Seat	1
50	Retaining ring	1
51	O ring	1
52	Steel ball	1
53	Seat	1
54	Outlet Valve body	1
55	Screw	5
56	O ring	1
57	Plug	1
58	O ring	1
59	Spring	1
60	Steel ball	1
61	O ring	1
62	Pipette tip	1
63	O ring	1
64	Valve filter	1
65	Valve Spring	1
66	O ring	1
67	Nozzle	1
68	Pipe	1
69	O ring	1
70	Connector	1
71	Pin	1
72	Heat protector	1

Parts Diagram: PW3500 Engine

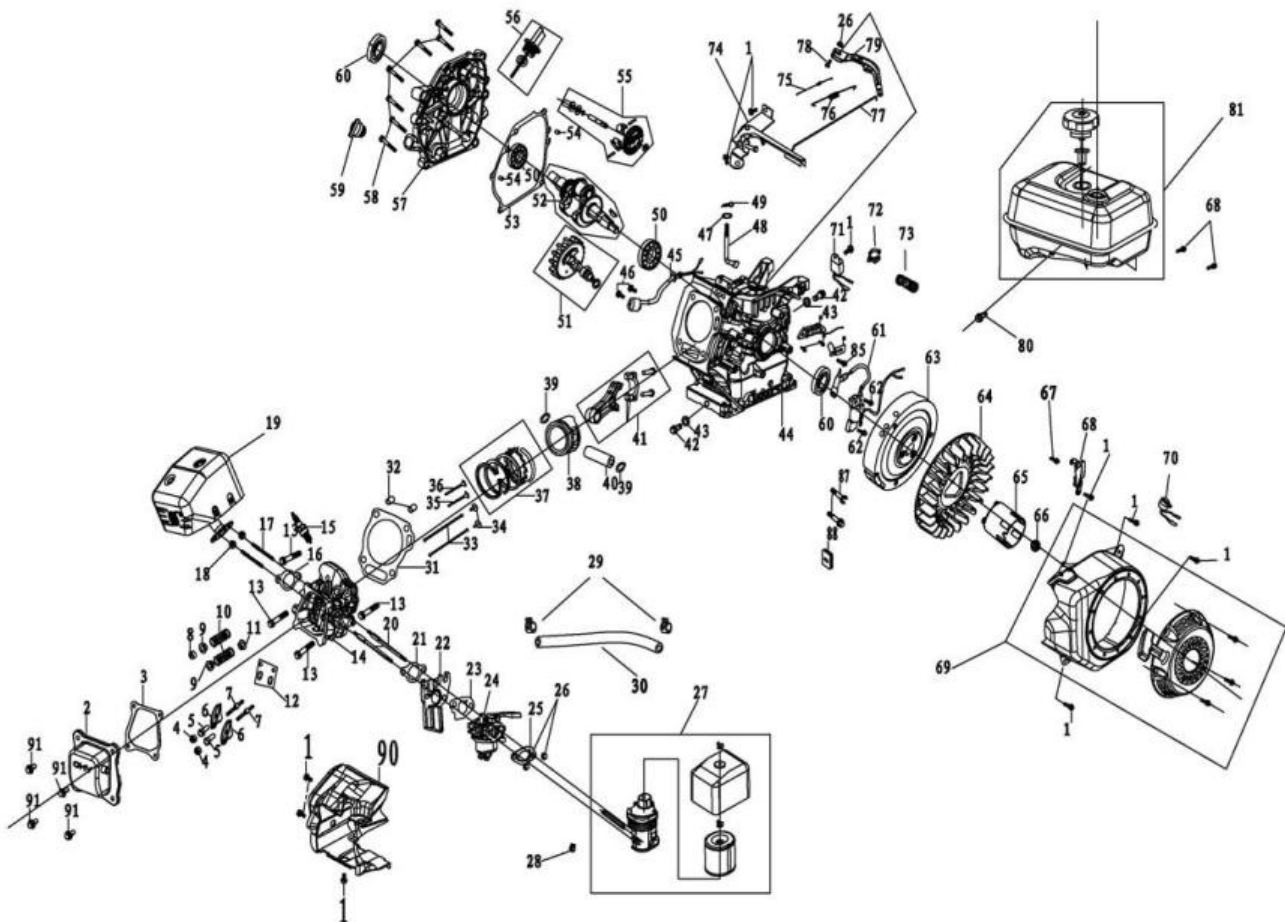

No.	Item Description	Qty
1	Bolt	13
2	Cylinder head cover assembly	1
3	Cylinder head cover gasket	1
4	Nut	2
5	Bolt	2
6	Valve rocker arm	2
7	Rocker shaft	2
8	Exhaust valve rotor	1
9	Exhaust valve Spring seat	1
10	Valve Spring	2
11	Intake valve Oil cover	2
12	Push rod guide	1
13	Bolt	2
	Bolt	2
14	Cylinder head assembly	1
15	Spark plug	1
16	Muffler gasket	1
17	Bolt	2
18	Nut	2
19	Muffler assy	1
20	Bolt	2
21	Seal gasket	1
22	Carburetor connection block	1
23	Carburetor gasket	1
24	Carburetor assy	1
25	Air filter gasket	1
26	Nut	2

No.	Item Description	Qty
27	Air filter assy	1
28	Clamp	1
30	Fuel pipe	0.165
31	Cylinder head gasket	1
32	Pin	2
33	Valve push rod	2
34	Valve lifter	2
35	Inlet valve	1
36	Exhaust valve	1
37	Piston ring assy	1
38	Piston	1
39	Clamp	2
40	Clamp	1
41	Rod assy	1
42	Bolt	2
43	Gasket	2
44	Crankcase	1
45	Oil sensor	1
46	Bolt	2
47	Gasket	1
48	Speed control rod	1
49	Clamp	1
50	Bearing	2
51	Camshaft assy	1
52	Crankshaft assy	1
53	Gasket	1
54	Pin	2

No.	Item Description	Qty
55	Speed control gear	1
56	Dipstick assembly	1
57	Crankcase cover	1
58	Bolt	6
60	Oil seal	2
61	Ignition coil assembly	1
62	Bolt	2
63	Fly wheel	1
64	Fan	1
65	Starting cup	1
66	Nut	1
67	Bolt	1
68	Side windshield	1
69	Recoil starter assy	1
70	switch	1
71	Oil alarm	1
72	Clamp	1
73	Pipe	1
74	Speed controller assembly	1
75	Spring	1
76	Spring	1
77	Speed control rod	1
79	Speed control arm	1
80	Bolt	1
81	Fuel tank assy	1
82	Nut	2
90	Wind shield cover	1

Parts Diagram: PW3500 Frame

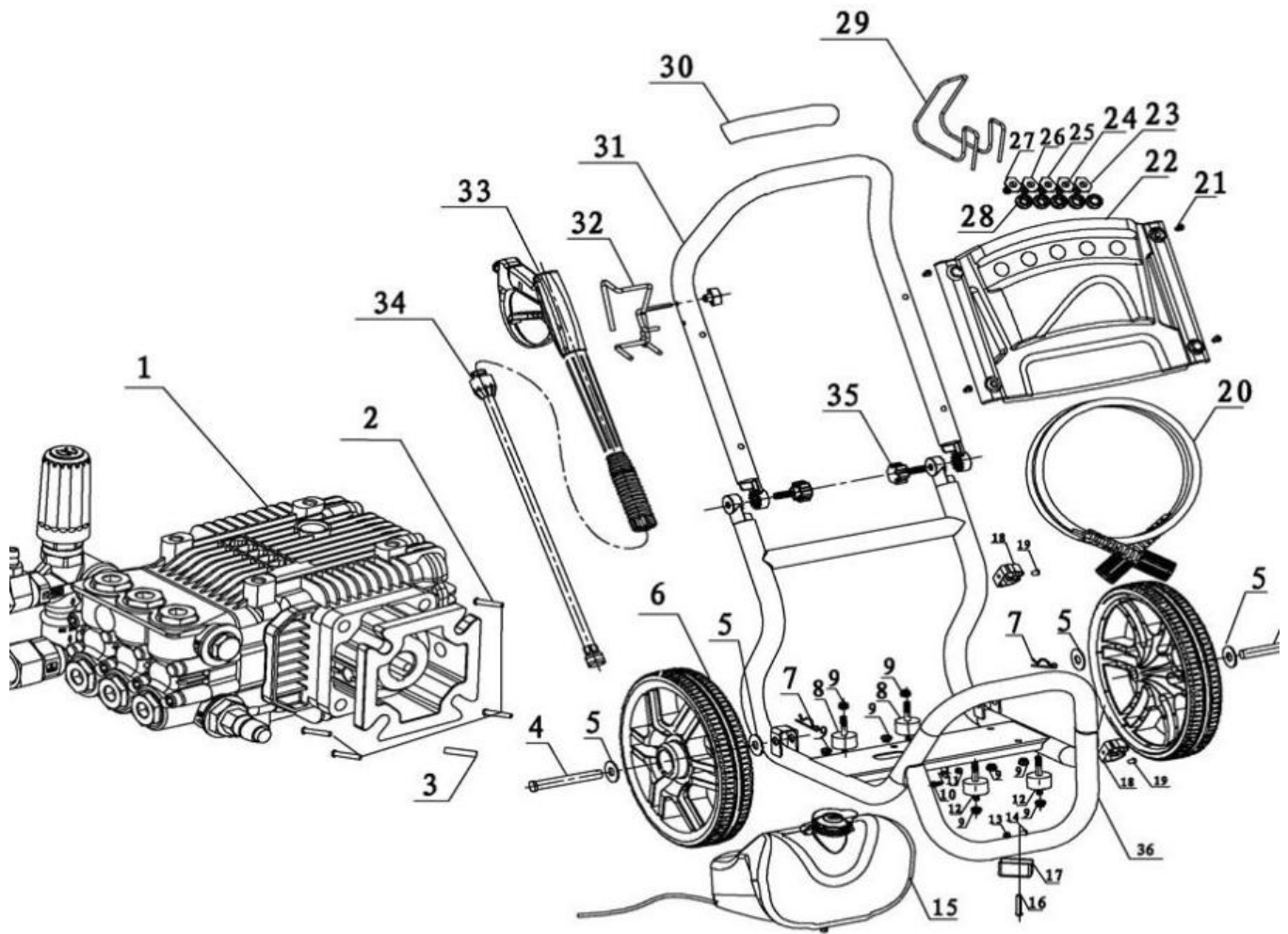

No.	Item Description	Qty
1	Pump assy	1
2	Bolt	4
3	Flat washer	1
4	Axle	2
5	Flat washer	4
6	wheel	2
7	Pin	2
8	Shock mount	2
9	Nut	8
10	Bolt	1
11	Nut	1
12	Shock mount	2
13	Nut	1
14	Bolt	1
15	Water tank	1
16	Bolt	1
17	Damping rubber pad	1
18	Bracket	2

No.	Item Description	Qty
19	Bolt	2
20	High pressure hose	1
21	Bolt	4
22	Nozzle panel	1
23	Nozzle	1
24	Nozzle red	1
25	Nozzle yellow	1
26	Nozzle green	1
27	Nozzle white	1
28	Nozzle holder	5
29	High pressure pipe hook	1
30	Handle rubber sleeve	1
31	Handle	1
32	Frame for Spray gun	1
33	Spray gun	1
34	Spray lance	1
35	Bolt	2
36	Frame	1

Parts Diagram: PW3500 Pump Kit

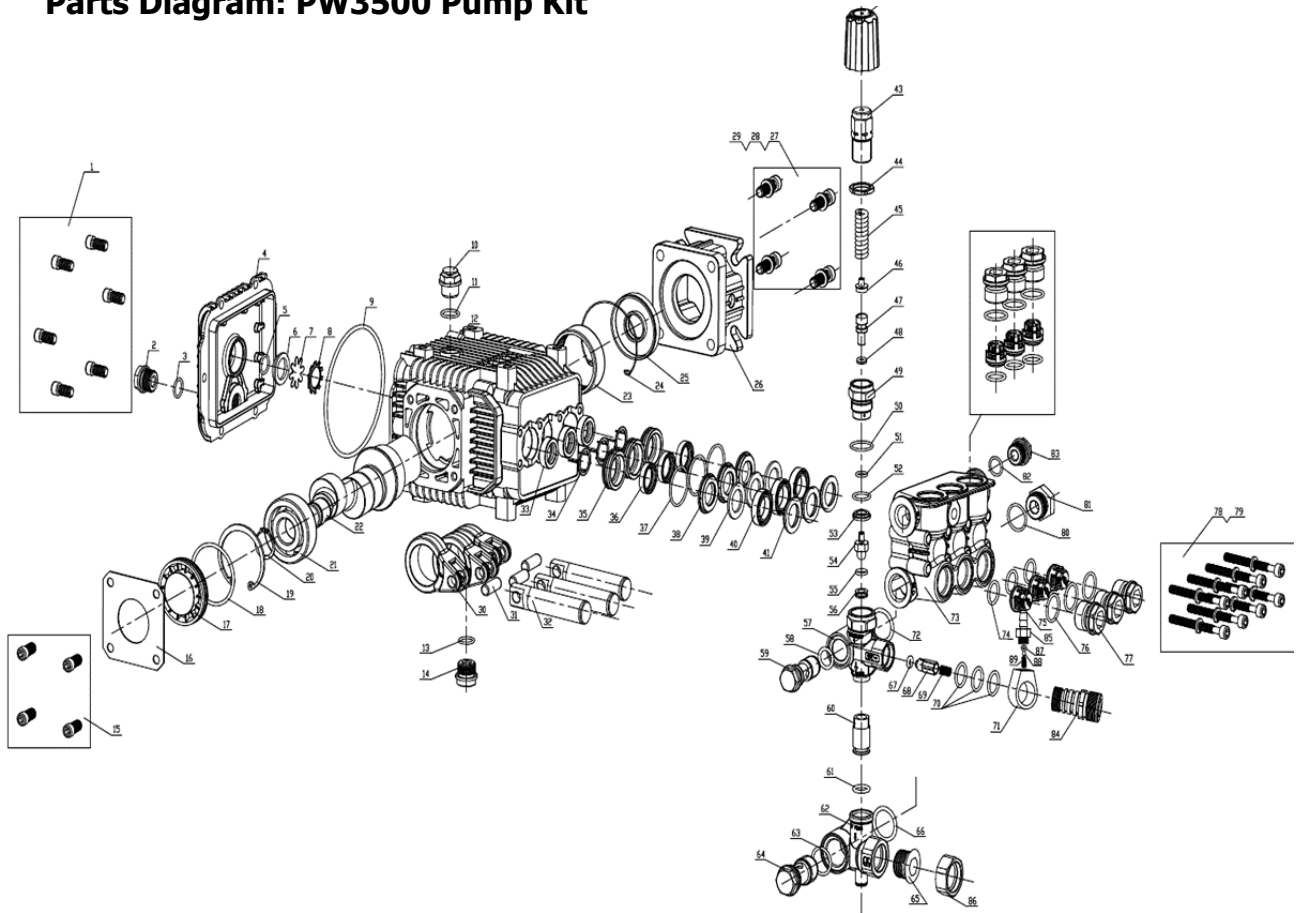

No.	Item Description	Qty
1	Inner Hexagonal Bolt	6
2	Oil Drain Bolt	1
3	O Seal Ring	1
4	Rear Cap	1
5	O Seal Ring	1
6	Rear Oil Level	1
7	Oil Level Indicator	1
8	Circlip	1
9	O Seal Ring	1
10	Fuel Filter Cap	1
11	O Seal Ring	1
12	Crank Chamber	1
13	O Seal Ring	1
14	3/8 Plug	1
15	Inner Hexagonal Bolt	4
16	Pressure Plate	1
17	Side Oil Cap	1
18	O Seal Ring	1
19	Internal Circlip	1
20	Internal Circlip	1
22	Crank	1
23	Needle Bearing	1
24	Circlip	1
25	Crank Oil Seal	1
26	Flange	1
27	Bolt Assembly	4
30	Connecting Rod	3
31	Plunger Pin	3
32	Plug	3
33	Plunger Oil Seal	3

No.	Item Description	Qty
34	Carriage	3
35	Rear Guide Sleeve	3
36	Auxiliary Water Seal	3
37	O Seal Ring	3
38	Supporting Ring	3
39	Flat Gasket	3
40	Main Water Seal	3
41	Supporting Gasket	3
42	Voltage Regulating Handwheel	1
43	Voltage Regulating Tube	1
44	Check Nut	1
45	Voltage Regulating Spring	1
46	Spring Retainer	1
47	Voltage Regulating Valve Stem	1
48	O Seal Ring	1
49	Adjustable Valve Stem	1
50	O Seal Ring	1
51	Seal Assembly	1
52	O Seal Ring	1
53	Seal Guiding Gasket	1
54	Cone Valve	1
55	O Seal Ring	1
56	Valve Seat	1
57	Valve Body	1
58	O Seal Ring	1
59	Inlet Connector	1
60	Inlet Pipe	1
61	O Seal Ring	1
62	Check Valve Body	1
63	O Seal Ring	1

No.	Item Description	Qty
64	Return Connector	1
65	Connector Inlet Pipe	1
66	O Seal Ring	1
67	O Seal Ring	1
68	Outlet Valve	1
69	Spring Of Outlet Valve	1
70	O Seal Ring	3
71	Immibition Base	1
72	O Seal Ring	1
73	Cylinder Block	1
74	O Seal Ring	3
75	Valve	1
76	O Seal Ring	3
77	Valve Nut	3
78	Bolt Assembly	6
79	Bolt Assembly	6
80	O Seal Ring	1
81	1/2 Plug	1
82	O Seal Ring	1
83	3/8 Plug	1
84	Immibition Outlet	1
85	Immibition Connector	1
86	Inlet Connector	1
87		1
88	Filter	1
89		1
90	O Seal Ring	1
91		1
92		1
93		1